



- Features :
  - Constant voltage design
  - Universal AC input / Full range
  - Withstand 300VAC surge input for 5 seconds
  - Protections: Short circuit / Over load / Over voltage
  - Cooling by free air convection
  - Fully encapsulated with IP67 level (Note.7)
  - Fully isolated plastic case
  - Class II power unit, no FG
  - Class 2 power unit
  - Pass LPS
  - Suitable for LED related fixture or appliance (such as LED Decoration or Advertisement devices)(Note.11)
  - 100% full load burn-in test
  - Low cost, high reliability
  - 2 years warranty



■ GTIN CODE

MW Search: <https://www.meanwell.com/serviceGTIN.aspx>

SPECIFICATION



MODEL	LPV-60-5	LPV-60-12	LPV-60-15	LPV-60-24	LPV-60-36	LPV-60-48	
OUTPUT	DC VOLTAGE	5V	12V	15V	24V	36V	48V
	RATED CURRENT	8A	5A	4A	2.5A	1.67A	1.25A
	CURRENT RANGE	0 ~ 8A	0 ~ 5A	0 ~ 4A	0 ~ 2.5A	0 ~ 1.67A	0 ~ 1.25A
	RATED POWER	40W	60W	60W	60W	60W	60W
	RIPPLE & NOISE (max.) Note.2	80mVp-p	120mVp-p	120mVp-p	150mVp-p	150mVp-p	150mVp-p
	VOLTAGE TOLERANCE Note.3	±8.0%	±5.0%				
	LINE REGULATION	±1.0%					
	LOAD REGULATION	±6.0%	±2.0%				
	SETUP, RISE TIME Note.6	500ms, 20ms / 230VAC	500ms, 20ms / 115VAC at full load(for 5~36V) ; 500ms, 30ms / 230VAC		500ms, 30ms / 230VAC	500ms, 30ms / 115VAC at full load(for 48V)	
HOLD UP TIME (Typ.)	50ms/230VAC	16ms/115VAC at full load					
INPUT	VOLTAGE RANGE Note.4	90 ~ 264VAC	127 ~ 370VDC				
	FREQUENCY RANGE	47 ~ 63Hz					
	EFFICIENCY (Typ.)	76%	83%	83%	86%	86%	86%
	AC CURRENT (Typ.)	1.2A/115VAC	1A/230VAC				
	INRUSH CURRENT(Typ.)	COLD START 60A(twidth=525µs measured at 50% Ipeak) at 230VAC					
	MAX. No. of PSUs on 16A CIRCUIT BREAKER	3 units (circuit breaker of type B) / 6 units (circuit breaker of type C) at 230VAC					
LEAKAGE CURRENT	0.25mA / 240VAC						
PROTECTION	OVER LOAD	110 ~ 150% rated output power Protection type : Hiccup mode, recovers automatically after fault condition is removed					
	OVER VOLTAGE	5.75 ~ 6.75V	13.8 ~ 16.2V	17.25 ~ 20.25V	27.6 ~ 32.4V	41.4 ~ 48.6V	55.2 ~ 64.8V
ENVIRONMENT	WORKING TEMP.	-30 ~ +70°C (Refer to "Derating Curve")					
	WORKING HUMIDITY	20 ~ 90% RH non-condensing					
	STORAGE TEMP., HUMIDITY	-40 ~ +80°C, 10 ~ 95% RH					
	TEMP. COEFFICIENT	±0.03%/°C (0 ~ 50°C)					
	VIBRATION	10 ~ 500Hz, 2G 10min./1cycle, period for 60min. each along X, Y, Z axes					
SAFETY & EMC	SAFETY STANDARDS	UL879(except for LPV-60-5), UL1310(except for LPV-60-5), CSA C22.2 No. 207-M89(except for LPV-60-5, LPV-60-48), CAN/CSA C22.2 No. 223-M91(except for LPV-60-5, LPV-60-48), BIS IS15885(Note 12), EAC TP TC 004, IP67, IEC62368-1, BS EN/EN62368-1 approved					
	WITHSTAND VOLTAGE	I/P-O/P:3KVAC					
	ISOLATION RESISTANCE	I/P-O/P:>100M Ohms / 500VDC / 25°C/ 70% RH					
	EMC EMISSION	Compliance to BS EN/EN55032 (CISPR32) Class B, BS EN/EN61000-3-2 Class A, BS EN/EN61000-3-3, EAC TP TC 020					
	EMC IMMUNITY	Compliance to BS EN/EN61000-4-2,3,4,5,6,8,11, BS EN/EN55035, light industry level, EAC TP TC 020					
OTHERS	MTBF	5188.4K hrs min. Telcordia SR-332 (Bellcore) ; 732.1Khrs min. MIL-HDBK-217F (25°C)					
	DIMENSION	162.5*42.5*32mm (L*W*H)					
	PACKING	0.4Kg; 32pcs/13.8Kg/0.66CUFT					

NOTE

- All parameters NOT specially mentioned are measured at 230VAC input, rated load and 25°C of ambient temperature.
- Ripple & noise are measured at 20MHz of bandwidth by using a 12" twisted pair-wire terminated with a 0.1µf & 47µf parallel capacitor.
- Tolerance : includes set up tolerance, line regulation and load regulation.
- Derating may be needed under low input voltage. Please check the static characteristics for more details.
- The power supply is considered as a component that will be operated in combination with final equipment. Since EMC performance will be affected by the complete installation, the final equipment manufacturers must re-qualify EMC Directive on the complete installation again. (as available on [https://www.meanwell.com/Upload/PDF/EMI\\_statement\\_en.pdf](https://www.meanwell.com/Upload/PDF/EMI_statement_en.pdf))
- Length of set up time is measured at first cold start. Turning ON/OFF the power supply may lead to increase of the set up time.
- Suitable for indoor use or outdoor use without direct sunlight exposure. Please avoid immerse in the water over 30 minute.
- The ambient temperature derating of 3.5°C/1000m with fanless models and of 5°C/1000m with fan models for operating altitude higher than 2000m(6500ft).
- Products sourced from the Americas regions may not have the TUV/BIS/CCC logo. Please contact your MEAN WELL sales for more information.
- For any application note and IP water proof function installation caution, please refer our user manual before using. [https://www.meanwell.com/Upload/PDF/LED\\_EN.pdf](https://www.meanwell.com/Upload/PDF/LED_EN.pdf)
- This product is not intended for LED lighting luminaire applications in the EU and China.(In the EU and China the LPF/NPF/XLG/XLC/XLN series are recommended.)
- Products sourced from the China regions may not have the BIS logo, please contact your MEAN WELL sales for more information.

⊗ Product Liability Disclaimer : For detailed information, please refer to <https://www.meanwell.com/serviceDisclaimer.aspx>

**Mechanical Specification**

Case No. 976A Unit:mm Tolerance:±1

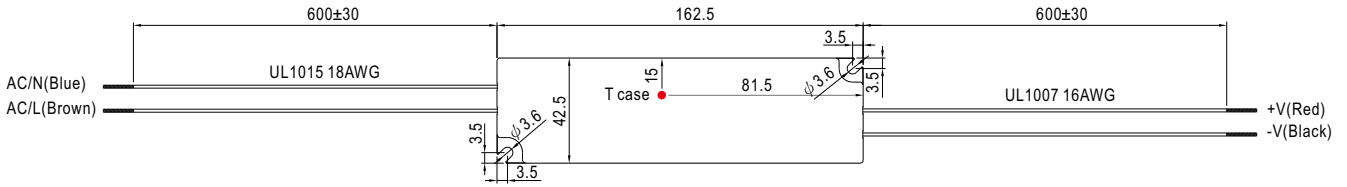

**Recommend Mounting Direction**

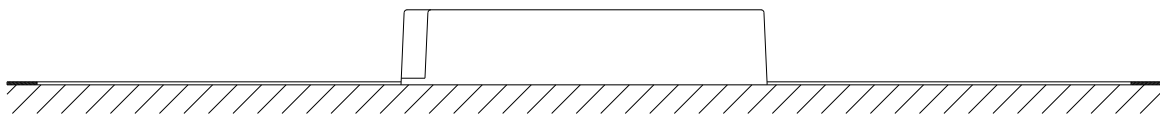

**Block Diagram**

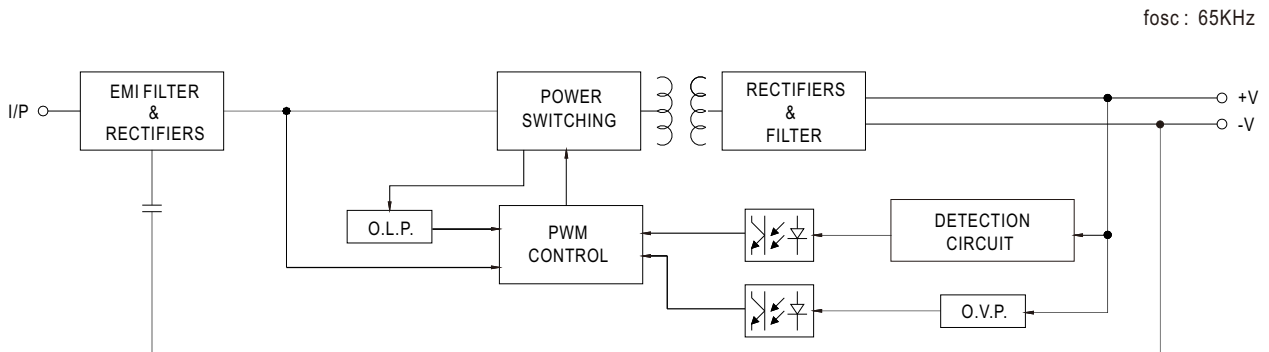

**Derating Curve**

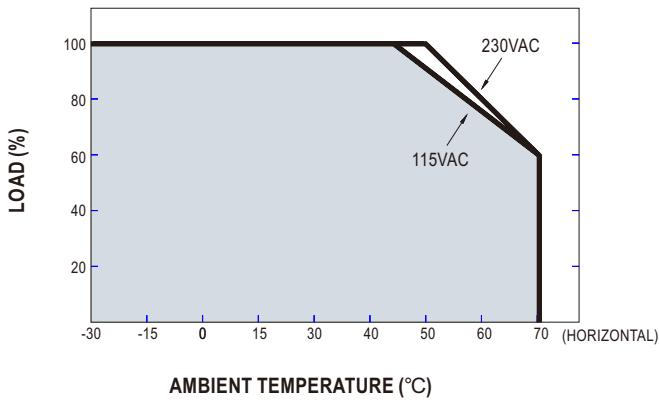

**Static Characteristics**

